

NASTRO-SB™ - X5 RANGE

The Next Benchmark



SEMI-AUTOMATIC CASE SEALER

100%
MADE in ITALY

NASTRO-SB™ - X5 RANGE

Nastro-SB™ X5 is a range of semi-automatic case sealing machines designed and engineered by SIAT specifically for small - medium fixed boxes. Nastro-SB™ X5 is the ideal case sealing machine for a variety of industries like food&beverage, chemical, clothes and wine.

SPECIFICATIONS

Max Production Capacity: 1200 boxes/hour

Case type: RSC - FEFCO 0201

Max case weight: 32 kg

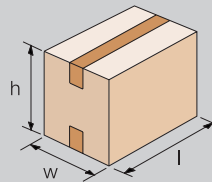

Box dimensions	L (mm)	W (mm)	H (mm)
X5S	150 - ∞	150 - 500	120 - 500
X5L	150 - ∞	105 - 500	50 - 500

KEY FEATURES

- » Seals upper & lower flaps of cardboard cases or cartons
- » Lockable electric
- » Central emergency stop to work on both sides safely
- » Best-In-Class components with SIEMENS electrics
- » Re-designed columns & upper frame to maximise strength and resist vibration
- » Quick release Taping Heads (Top & Bottom – No tools required)
- » Easy and quick belt conveyor maintenance

ENERGY SAVING VERSION

Motors and conveyors stop after a defined time when no cartons are detected



Top taping unit position
adjustment handle

Central emergency button

Top taping unit

Bottom taping unit

Easy to maintain
belt conveyor

On/off lockable switch

Belt conveyor position
adjustment handle

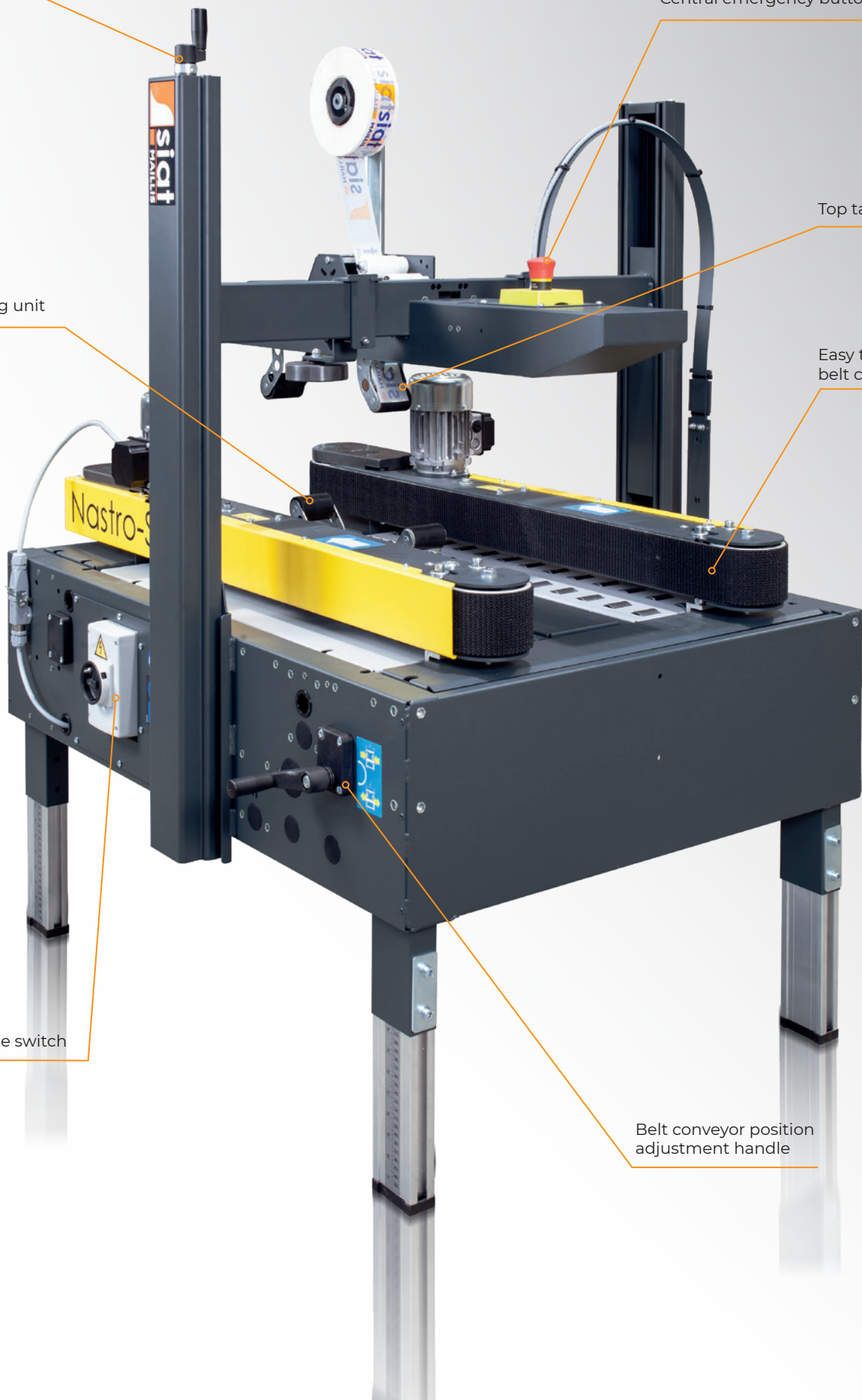

NASTRO-SB™ - X5 RANGE

Machine dimensions

Dimensioni macchina
Maschinenabmessungen
Dimensions machine
Dimensiones de máquina

	Min (mm)	Max (mm)
Total H	1375	1635
H Bench	540	800
W	950	900
W Bench	800	800
L	1100	1100

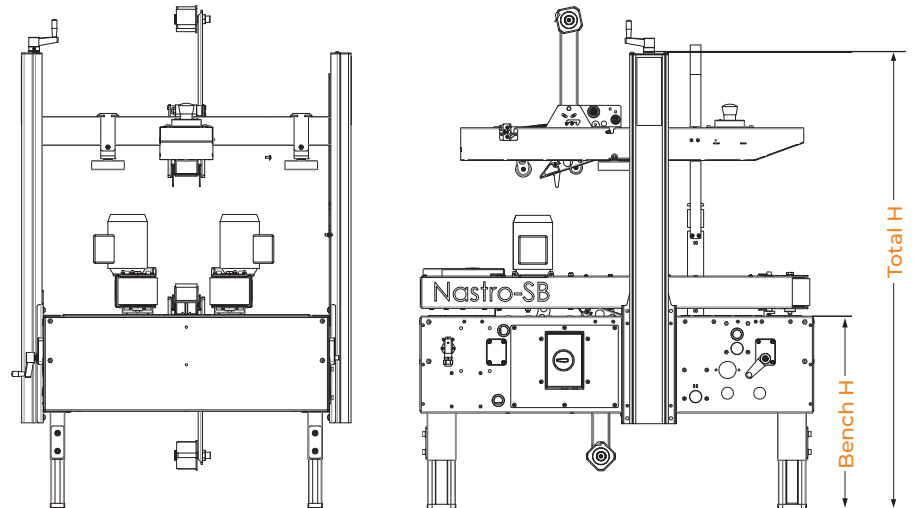

 **185 Kg**

 **220 Kg**

 **120(L) x 106(w) x 116(H) cm**

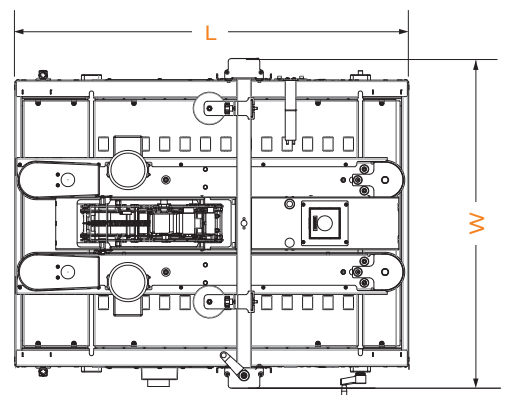

Max Production capacity

Capacità di produzione
Produktionskapazität
Capacité de production
Capacidad de producción

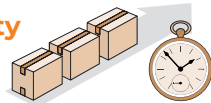

up to 1200 Bph

Standard power supply

Alimentazione standard
Standard-Stromanschluß
Alimentation électrique standard
Fuente de alimentación estándar

380/415V - 50Hz - 3ph	
440V - 60Hz - 3ph	
Amps	1,08
Power kW	0,18
Phase	3Ph + N + PE

Optional Extras

Accessori
Zubehör
Accessories
Accesorios

GTL - GTR

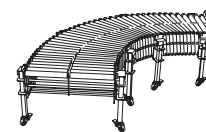

Higher Legs



Nastro legs medium height (440-700 mm)
Nastro legs max height (760-1020 mm)

AS77

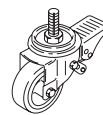

RG

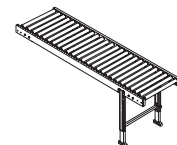

SIAT Spa

Via Puecher 22, 22078 Turate - Como
www.siat.com

 **100%**
MADE in ITALY

SIAT AND MAILLIS GROUP

SIAT is the famous Italian Brand of strapping hand tools, semi-auto wrappers and case handling machines and proudly part of Maillis Group. Operating 5 production units around the

world and employing over 1,200 qualified staff, Maillis provides you with reliable system solutions incorporating machines, consumables and services to face your everyday challenges across different industries.

SIAT S.p.A is recognised worldwide as a top-class machine manufacturer for secondary packaging and produces more than 17,000 machines per year, and has done since 1970. Our product range includes semi-automatic as well as fully automatic machines like Case Sealers and Case Erectors, Stretch Wrappers, Strapping Tools / Machines, Flexographic Printing Machines and Tape Dispensers. The company is present in more than 100 countries and is constantly investing worldwide to meet customers actual and future demands.