

hacona[®]

C-type V2.0

Impulse sealing machine
Instruction manual



Before using the machine please read carefully the
instruction manual!

Table of contents:

1.	Introduction.....	3
1.1.	Capacity of the sealing machine.....	3
1.2.	Identification of the machine.....	3
2.	How to set up the machine.....	4
2.1.	Transport and positioning of the machine	4
2.2.	Conditions of use.....	4
3.	Technical description.....	5
3.1.	Build-up.....	5
4.	Operation.....	5
5.	Setup and operation of the machine	6
5.1.	To-do before operation	6
5.2.	Electric connection	6
5.3.	Setup	7
5.4.	The use of the cutting knife	8
6.	Conditions and limitations of the machine's appropriate operation	9
6.1.	Technical parameters	9
6.2.	What is forbidden to package	9
7.	Safety provisions.....	9
8.	Machine maintenance	10
8.1.	Cleaning.....	10
8.2.	How to replace the wearing parts	11
8.2.1.	How to replace the teflon tapes and sealing wire	11
8.2.2.	How to replace the silicone rubber	12
8.2.3.	How to replace the knife	13
8.2.4.	How to replace the knife assembly	14
8.3.	Electric setup	16
8.4.	Opening the machine	17
8.5.	How to replace the fuse.....	17
8.6.	Wearing parts	18
8.7.	Handling of the waste	18
9.	Troubleshooting.....	19
10.	Guarantee	20
10.1.	Guarantee.....	20
10.2.	Conditions of guarantee	20
11.	Spare parts/ Ware parts.....	23
12.	EC Declaration of Conformity:	24

1. Introduction

This table impulse sealer is exceptionally easy to handle and indispensable in factories, offices and anywhere where packaging is necessary or the shelves need to be tied up. The machine is suitable for plastic bag preparation and sealing of plastic bags filled with goods.



In order to prevent damage and accidents due to misuse the machine can only be used by an operator trained to handle the machine and who read and understood the machine's user manual before starting the operation.

1.1. Capacity of the sealing machine

Types of film to be welded: **LDPE, HDPE, PP, PVC, BOPP.**

Possible film thickness: **10-200µm**

Sealing length (depending on type of machine): **220, 320, 420, 620mm**

Sealing width (all types of machine): **2.5mm**

The thickness of film to be welded may depend on the type of the film material. In every case it is advisable to carry out a trial sealing.

1.2. Identification of the machine

When contacting the customer service of the producer or the distributor about the product please note the type and the serial number of the machine that appears on the data table (**Figure 1**) on the back of the machine.

Letter "C" indicates that the machine is powder coated (orange), the sign "CI" means anodized (grey) finish with stainless fasteners. The numbers after the type code indicate the maximal sealing length.

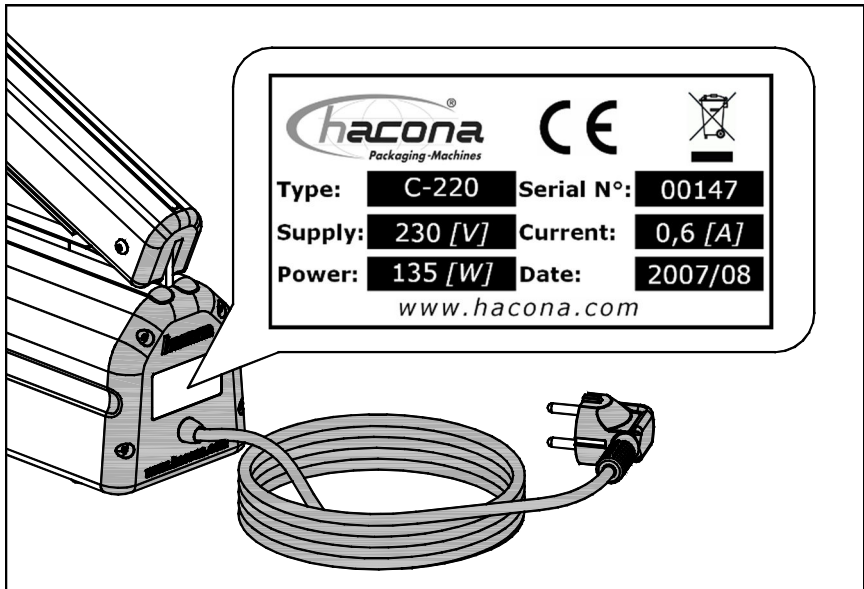

Figure 1 Data table

2. How to set up the machine

2.1. Transport and positioning of the machine

During transport and setup, handle the machine with great care. Carefully lift the machine out of the cardboard box.

After unpacking, it is advisable to put the machine on a worktable.

2.2. Conditions of use

The machine shall be operated and stores in a dry room with good ventilation away from inflammable materials, gases and other explosives.

Ideal operation room conditions:

Temperature:	between +5°C and +40°C
Relative humidity:	between 30% and 90%

3. Technical description

3.1. Build-up

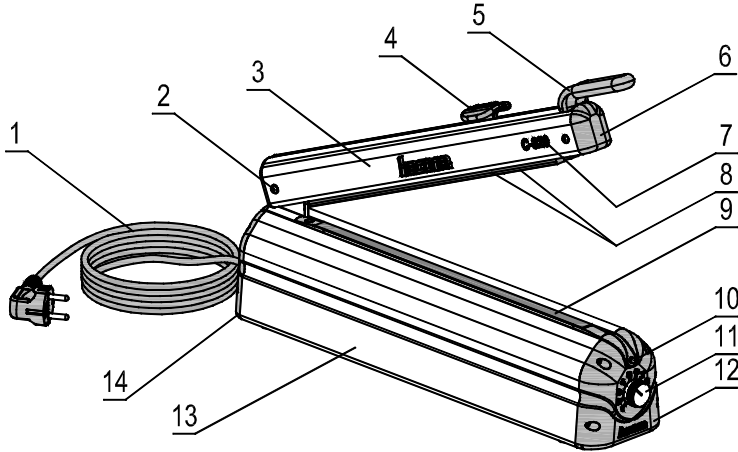

Figure 2 The build-up of sealing machine

- | | |
|----------------------------------|--|
| 1 – Grounded main electric cable | 9 – Sealing unit (sealing wire with upper and lower teflon tape) |
| 2 – Hinge bolt | 10 – LED (lamp) |
| 3 – Sealing bar | 11 – Regulator button |
| 4 – Knife assembly | 12 – Front cover |
| 5 – Handle | 13 – Machine frame |
| 6 – Front cap (magnetic) | 14 – Back cover |
| 7 – Machine type code | |
| 8 – Silicone rubber | |

4. Operation

After connecting to the electricity, but before starting the sealing, set the sealing time. Close the handle and push it down continuously until the sealing time ends (while the LED (lamp) lights red the machine is sealing)

and afterwards for 1-2 seconds so that the film cools down. Cut the film then lift the handle to default position.



For the appropriate operation of the machine it is necessary to read and fully understand the entire instruction manual.

5. Setup and operation of the machine

5.1. To-do before operation

Before starting the operation check that the machine is intact.



Do not use the machine if the connection plug, the cables or any other parts are damaged. Electric shock hazard!

5.2. Electric connection

Before connecting the machine to the electricity make sure that the electricity voltage is identical to the voltage value of the data table (**see: Figure 1**) on the back of the machine and that the grounded complies with the safety provisions. In case of any doubts please refer to the local Electricity Supplier.

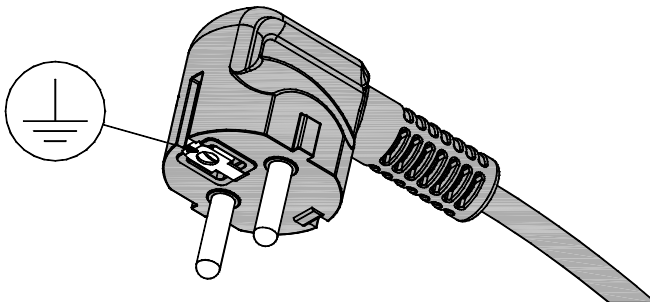

Figure 3 Grounded electric plug

FOLLOW THE SAFETY REGULATIONS OF THE WORKPLACE.
NEVER USE THE MACHINE WITHOUT GROUNDING.

5.3. Setup

The machine is ready for operation after it is connected to the electricity network. The yellow light of the LED (lamp) indicates the ready state. (**Figure 4 “a”**).

The correct sealing time should be set referring to the type and width of the used film. For effecting a trial sealing set the sealing time regulatory button (**Figure 4 “b”**) to the lowest setting (1). Place the film between the sealing head and the sealing electrode. Close the sealing head and wait for the end of the sealing time while continuously pushing it down. During sealing the light of the LED (lamp) (**Figure 4 “a”**) changes from yellow to red. In order to achieve a perfect seal it is advisable to keep the handle down for a few seconds after the sealing ends so that the seal cools down under pressure and becomes extremely solid. After the cool down time lift the handle and the seal is ready.

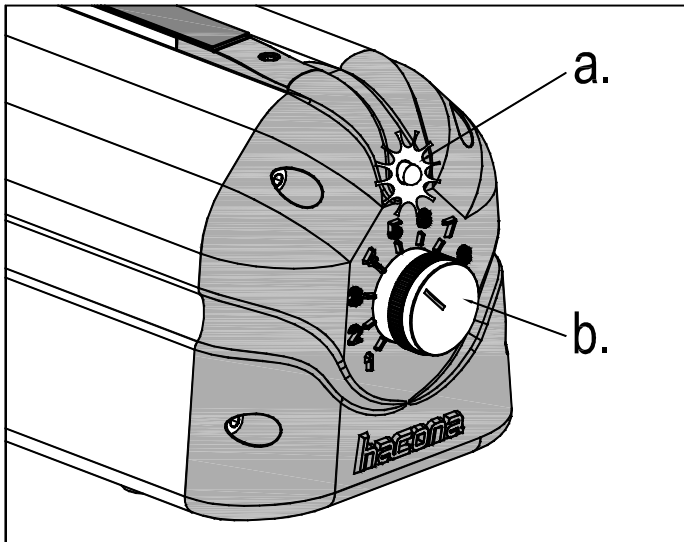

Figure 4 Operation setting

If the sealing of the film is not perfect or the bag is not sealed properly, the sealing time has to be increased by changing the sealing time regulatory button (**Figure 4 “b”**) to a higher setting.

The trial sealing always has to be carried out at a low setting and if necessary the value needs to be increased by small steps. Sealing carried

out at a higher temperature than necessary, may result in the premature wear of parts and the excessive melting of packaging material.



Never weld without film.

5.4. The use of the cutting knife

The knife is pulled back by a spring for safety reasons. By pressing down the knife and moving it back and forth the film can be cut during the sealing time. With the same operation, bags can be prepared from a film roll (tube film).

Note: In order to achieve the best cutting result press the head of the knife down at the middle of the film which is sealed and push forward and backwards. This can prevent the breaking of film at the sides. (Figure 5).

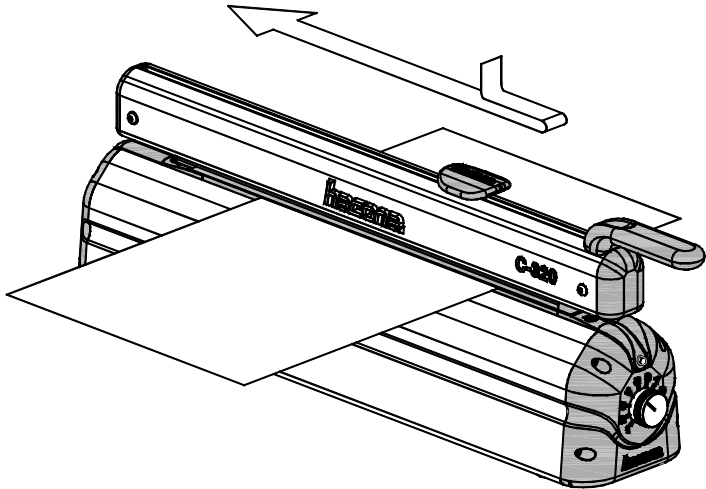

Figure 5 Correct cutting technique



Never press down the knife head when the sealing bar is open as the sharp knife may cause injuries. Before each use

always check that the knife is intact and that it is at its correct position.

6. Conditions and limitations of the machine's appropriate operation

6.1. Technical parameters

Type	Sealing length [mm]	Maximal film width [mm]	Cutting length [mm]	Machine dimension [mm]	Net weight [kg]
C - 220	220	200	200	433x100x175	3,10
C - 320	320	300	300	533x100x175	3,60
C - 420	420	400	400	633x100x175	4,05
C - 620	620	600	600	833x100x175	4,95
CI - 220	220	200	200	433x100x175	3,05
CI - 320	320	300	300	533x100x175	3,55
CI - 420	420	400	400	633x100x175	4,00
CI - 620	620	600	600	833x100x175	4,90

During appropriate use the heating wire can only heat up to 125°C.

6.2. What is forbidden to package

In order to avoid continuous hazard of operator and machine it is forbidden to pack the following materials:

Wet product, liquids, inflammable material, and any other material not mentioned here that might endanger the health of operators and/or the safe operation of the machine.

7. Safety provisions



**Never touch the sealing wire directly after sealing.
Burning hazard.**



The machine must be disconnected from the electric network if the sealing wire brakes. The broken sealing wire must be changed. Electric shock hazard.



Check the correct position of machine on the worktable. Hazard of accident.



Before use, always check that the knife is intact and is at its correct position. Hazard of accident.



Do not use the machine in wet conditions, do not splash with water or immerse it in water. Hazard of electric shock.



Regularly check the state of the network cable and the plug. Hazard of electric shock.

8. Machine maintenance



**BEFORE STARTING ANY MAINTENANCE ACTIVITY
UNPLUG THE MACHINE!**

8.1. Cleaning

The machine does not require special care. It is advisable to remove film residues from the sealing head and silicone rubber before they burn on. Use slightly wet cloth for cleaning. Do not use cleaning products containing solvents.



Before cleaning the network plug must be removed from the electric supply. Hazard of electric shock.



During cleaning be careful with the sharp knife built in the sealing bar. Hazard of accident.



During cleaning do not use any tools or solvents that might damage the teflon tapes and the silicone rubber.

8.2. How to replace the wearing parts



When changing any parts use only original HACOMA spare parts. The use of materials that are not original results in the invalidity of the guarantee.

8.2.1. How to replace the teflon tapes and sealing wire

Used, burned teflon tapes have to be change without delay for safe operation.

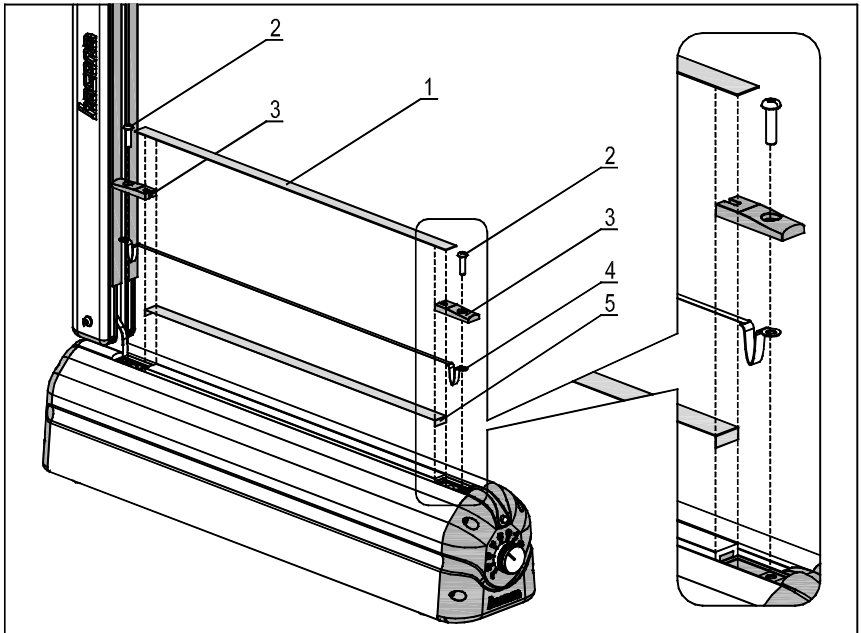

Figure 6 How to replace the teflon tapes and sealing wire

Remove the upper teflon tape (**Figure 6 “1”**), then unscrew the fastening screws on the side of the sealing electrode (**Figure 6 “2”**). Remove the safety caps of the sealing wire tensioning units (**Figure 6 “3”**) then pulling up the sealing wire (**Figure 6 “4”**) carefully remove from the machine unit. Remove the teflon tape (**Figure 6 “5”**) attached to the machine unit.



Cut the lower self adhesive teflon tape (Figure 6 “5”) on each side 4 mm longer than the side panel of the aluminium machine unit in order to prevent electric short circuit.



Use only original HACONA spare parts.



The surface of the sealing wire (Figure 6 “4”) can never be taped, it has to be able to move freely under the upper teflon strap. The upper teflon strap is not adhesive all the way.

Note: When changing the teflon tape always check whether the teflon tape under the sealing wire is intact. When changing the sealing wire it is advisable to put on the protective cap of the backwards sealing wire tensioning unit.

8.2.2. How to replace the silicone rubber

Pull out the damaged or burnt silicone rubber (profile) from the sealing bar and clip in a new silicone rubber (Figure 7).



The silicone rubber does not have to be pulled in the profile. It can be clipped in easily.



When putting the silicone rubber in, watch out for the direction of the profile. Looking from the sealing bar as it opens the profile should look like the picture. (Figure 7).

HAZARD OF ACCIDENT.



When changing the silicone rubber be careful with the sharp knife built in the sealing bar’s knife assembly (Figure 7).

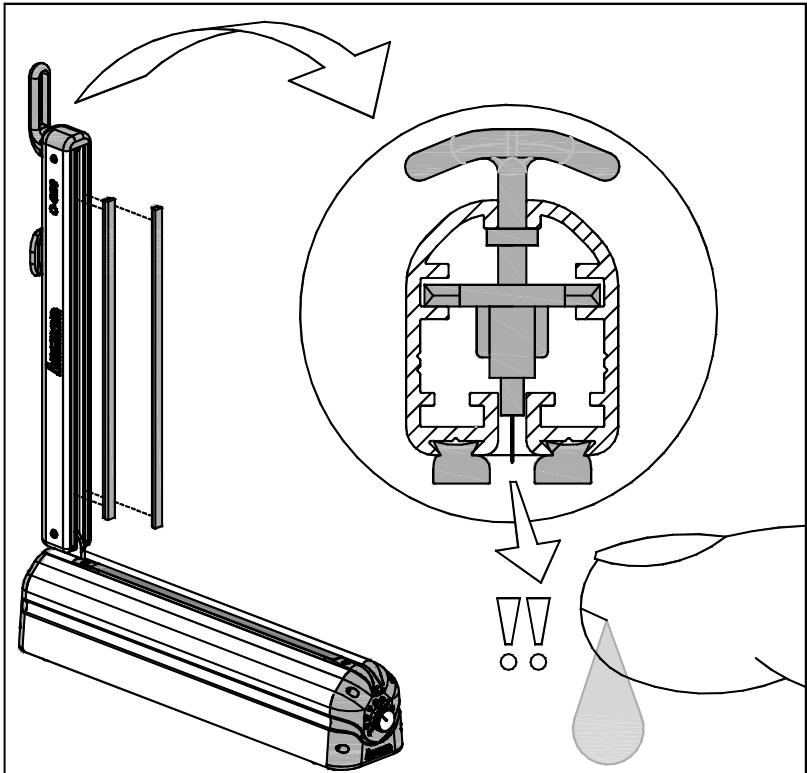

Figure 7 How to replace the silicone rubber.



Only use original HACONA spare parts.

8.2.3. How to replace the knife

To change the blunt, dull or broken knife lift the sealing bar and press down the head of the knife assembly. Pull the knife out with pliers from its housing (**Figure 8**). Change it to a new one.

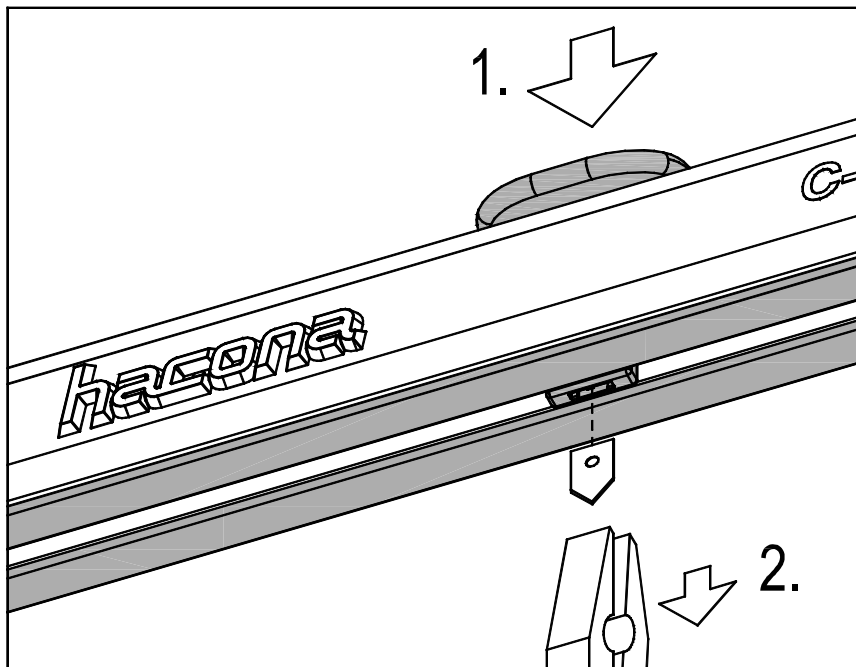

Figure 8 How to replace the knife



Hazard of injury.



Always wear protective gloves during operation.



Only use original HACONA spare parts.

8.2.4. How to replace the knife assembly

The worn out or damaged knife assembly must be replaced. Remove the front cap of the sealing bar from the front side of the sealing bar as it opens (Figure 9, a/1). Please loosen the screws holding the handle, and

then remove it (**Figure 9, a/2**). Fully detach the screws fastening the sealing head (**Figure 9, b/3**). Remove the spreader from the two aluminium profiles (**Figure 9, b/4**). Pull out the old knife assembly (**Figure 9, c/5**).

After replacing the knife assembly build up the sealing head by carrying out the above-mentioned actions in opposite order.

Note:

Always put the front cap back or the machine will not work!

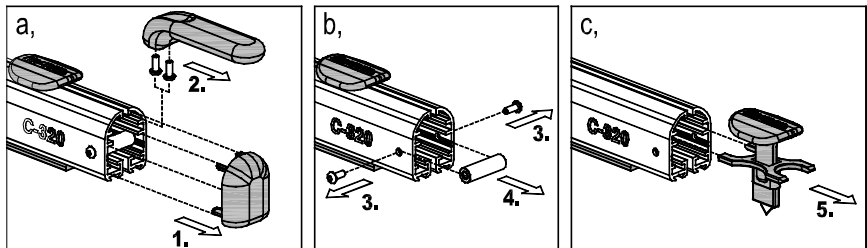

Figure 9 How to replace the knife assembly



Only use original HACONA spare parts.



Hazard of injury.



Always wear protective gloves during operation.

8.3. Electric setup

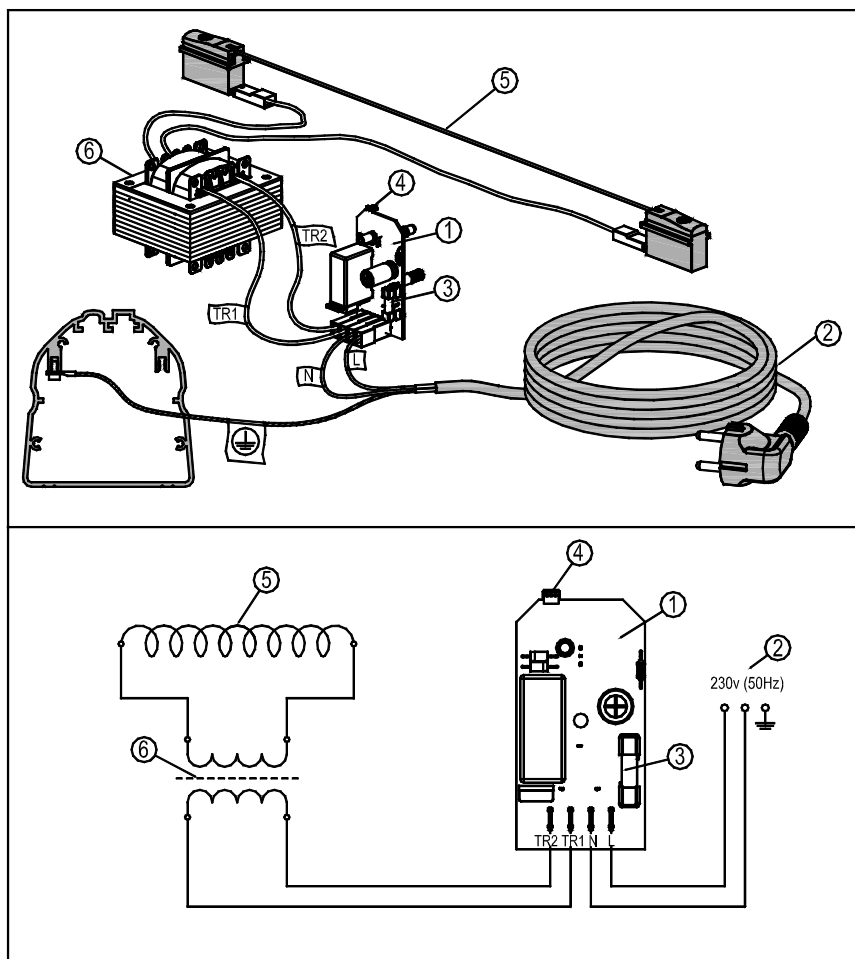

Figure 10 Electric switch

List of parts:

- | | |
|----------------------------------|--------------------------|
| 1 – Control panel | 4 – Switch (Hall-sensor) |
| 2 – Grounded main electric cable | 5 – Sealing wire |
| 3 – Fuse (2,5 A) | 6 – Safety transformer |

Technical parameters:

Type of transformer	Primer/Secondary voltage	Nominal electric power	Nominal current
C-220/CI-220	230/10V	135 W	0.60 A
C-320/CI320	230/15V	175 W	0.80 A
C-420/CI-420	230/19V	220 W	1,00 A
C-620/CI-620	230/27V	320 W	1.45 A

The electric power of every machine during idle time is less than 8 W.

Electric shock protection rating: First class

IP code: **IP20**

8.4. Opening the machine



The reparation and the internal setup of the machine can only be carried out by a trained specialist.



When opening the machine always unplug from the electricity network.

8.5. How to replace the fuse

The fuse is on the control panel built inside the front cover (**Figure 2 “12”**) of the machine. When opening the machine always follow the provisions described above.

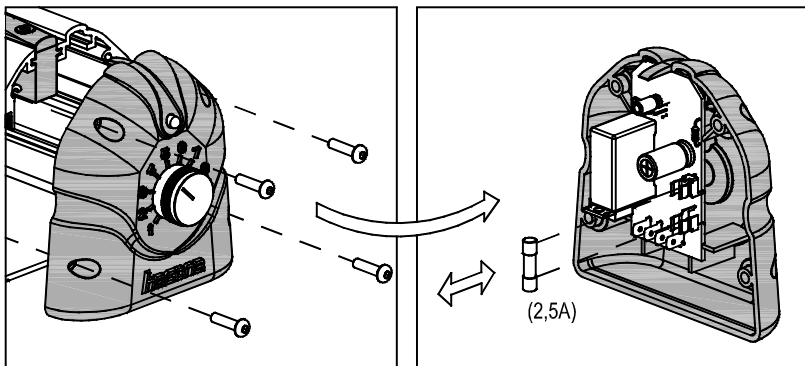

Figure 11 How to replace the fuse

8.6. Wearing parts

- 1-Silicone rubber
- 2-Upper teflon tape
- 3-Sealing wire

- 4-Lower teflon tape
- 5-Knife assembly
- 6-Cutting blade

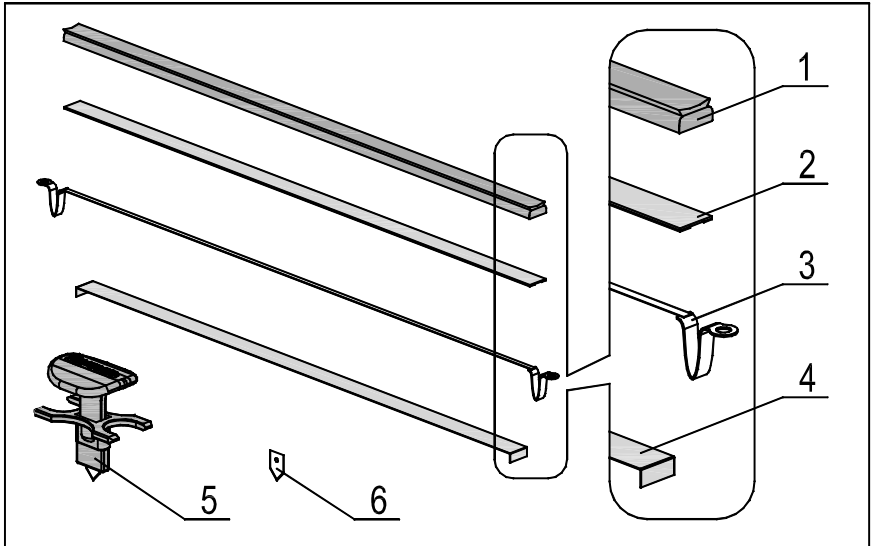

Figure 12 Wearing parts

8.7. Handling of the waste

The purchased product may contain parts considered hazardous waste therefore do not dispose of the unit as communal waste as it might damage the environment. Selective collection is available for the product. After assessment all waste should be collected, transported, recycled or disposed of according to the relevant regulations of the place of repair.

9. Troubleshooting

<p>The machine does not weld, and the LED (lamp) does not light yellow or red.</p>	<ul style="list-style-type: none"> • Check whether the machine is connected to 230V electricity supply and if the network is working. • The control panel is damaged.
<p>The machine does not weld. The LED (lamp) has yellow light, but it does not change red when closing the handle.</p>	<ul style="list-style-type: none"> • Make sure that the handle is pressed down with enough strength. (Do not press the handle sideways.) • Check whether the front cap is on the handle and the magnet is in it. • The control panel is damaged.
<p>The machine does not weld; the LED (lamp) is lit appropriately (yellow/red changes operationally).</p>	<ul style="list-style-type: none"> • Unplug from the electricity supply without delay. Check that the sealing wire, the teflon tapes and the transformer are intact.
<p>The sealing is not acceptable.</p>	<ul style="list-style-type: none"> • Change the sealing time with the regulatory button. (The sealing time increases proportionally with the width of the film.) • Make sure that you wait for the adequate cooling time after sealing. (1-2 sec.) The cooling time increases proportionally with the sealing time.
<p>The handle clacks sideways, it is loose.</p>	<ul style="list-style-type: none"> • The hinge bolts have to be fastened.
<p>When connecting to the electricity supply the sealing wire start to heat up immediately.</p>	<ul style="list-style-type: none"> • The control panel is damaged. Unplug from the electricity supply without delay and refer to the repair facility.

10. Guarantee

10.1. Guarantee

The guarantee is valid for 12 months after the purchase. The guarantee can only be vindicated if the original receipt is shown.

10.2. Conditions of guarantee

The guarantee covers material defects and replacement, repair of parts with production defects. The replacement, repair of parts with defects take place at premises of the producer or its official distributor. The transport costs are always covered by the customer.

For transport the machine must be wrapped up in the original packaging material with the use of protective elements (**Figure 13**). If the original packaging material is not available, the machine might be wrapped in a different way with great care. Any damage occurring during transport is not covered by the guarantee.



Repair covered by guarantee can only be carried out by the producer or its representative.

The guarantee is not valid:

- If the original purchase receipt cannot be presented.
- If the machine was opened unjustifiably without authorization.
- If the machine was repaired with parts that are not original.
- If the machine was not set up properly, it was connected to unsuitable electricity supply, it was operated or maintained differently to what is explained in the manual, and/or was neglected or damaged on purpose.
- If constructional changes were carried out on the machine without the prior written consent of the producer.
- If the machine was operated inappropriately.
- If the machine is not owned by the first purchaser.

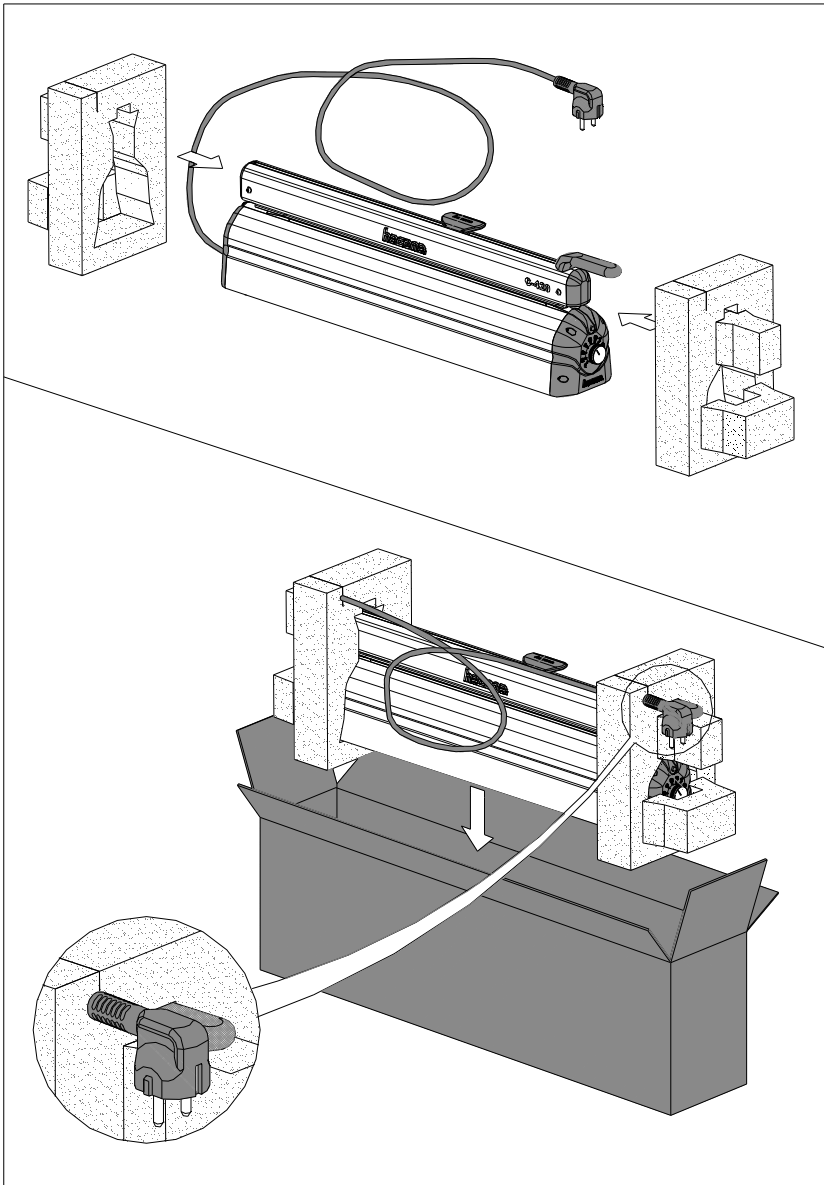

Figure 13 The correct packing of the machine.

According to relevant legislations all liability is relinquished in the case of injuries and damage of objects where the machine has not been set up appropriately, is connected to the electric supply improperly or without grounding, the machine is not operated by a trained operator, the machine was opened without authorization, the machine was altered or was not used appropriately.

The producer reserves the right to carry out technical or functional changes on the products as new innovation without any special notification



Guarantee cannot be vindicated for the wearing parts described in chapter 8.2.



The damaged electric cable and plug can only be changed by the producer or its assigned repair facility.



The machine must only be repaired with special tools.

11. Spare parts/ Ware parts

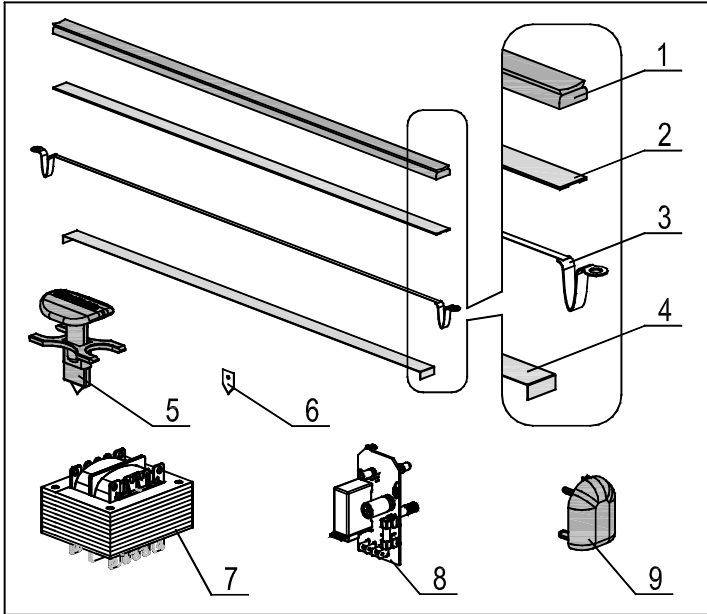

Order No.							
Pos	Description	Type					In meter
		C-220 CI-220	C-320 CI-320	C-420 CI-420	C-620 CI-620	C-820 CI-820	
1	Silicone rubber	HA 004-453	HA 004-454	HA 004-455	HA 004-456	HA 004-457	HA 000-427
2	Upper teflon tape						HA 000-578
3	Sealing wire pack *	HA 001-334	HA 001-335	HA 001-336	HA 001-337	HA 005-252	-
4	Lower teflon tape						HA 000-606
5	Knife assembly	HA 000-420 or HA 004-352					-
6	Cutting blade	HA 000-414 (6pcs/unit)					-
7	Safety transformer	HA 004-750	HA 004-671	HA 004-928	HA 004-929	HA 004-260	-
8	Control panel	HA 000-814					-
9	Front cap (magnetic)	HA 003-308					-

* This sealing wire pack contains the sealing wire the upper and the lower teflon tape.

12. EC Declaration of Conformity:

Hereby HACONA Kft.

✉ Újszász utca 45/B, „T”-building
H-1165 Budapest,
HUNGARY

☎ +36 (1) 401-3030

📠 +36 (1) 401-3031

@ mail@hacona.com

🌐 www.hacona.com

declares being fully aware of the legal liability, that the following Impulse sealing machine

Type:

Serial number:

complies with the following provisions and their modifications:

2006/42/EC	Machinery Directive 98/37/CE
2006/95/EC	Low Voltage Directive
2004/108/EC	EMC Directive

and state that the provisions of the following standards were taken into account:

EN ISO 12100-1:2003. Safety of machinery. Basic concepts, general principles for design. Part 1: Basic terminology, methodology
EN ISO 12100-2:2003. Safety of machinery. Basic concepts, general principles for design. Part 2: Technical principles
EN 60204-1:2006. Safety of machinery. Electrical equipment of machines.

Budapest,

Lajos Nagy

Mechanical engineer MSc
Managing director